



**Institute of
Applied Physics**

Friedrich-Schiller-Universität Jena

Scanning Quantum Microscopy

Frank Setzpfandt

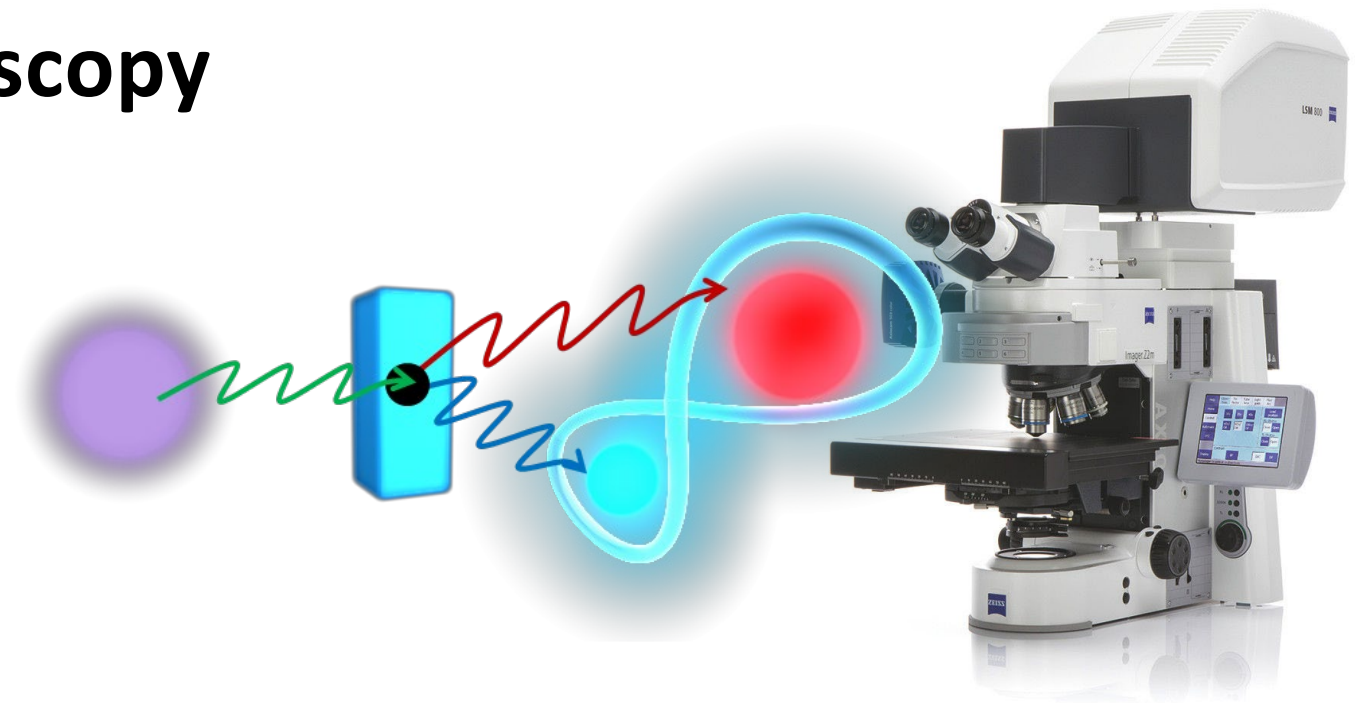

Photonica 2023, 28.08.2023

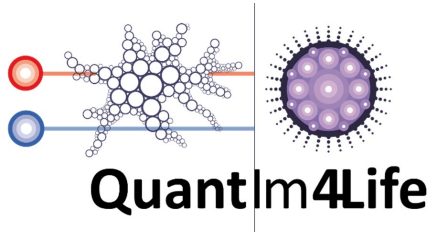

Mina Afsharnia
Vira Besaga
Dupish
Valerio Gili
Mohit Kumar
Elkin Santos
Andres Vega

other group members

Anna Fedotova
Pawan Kumar
Franz Löchner
Sina Saravi
Maximilian Weissflog
Mohammadreza Younesi

Collaborators

Fondazione Bruno Kessler, Italy
Fraunhofer IOF, Jena

Funding



Spontaneous parametric down conversion (SPDC)

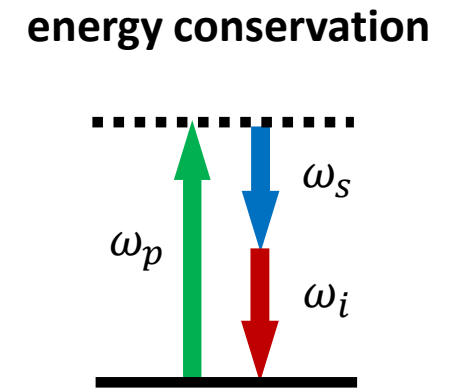
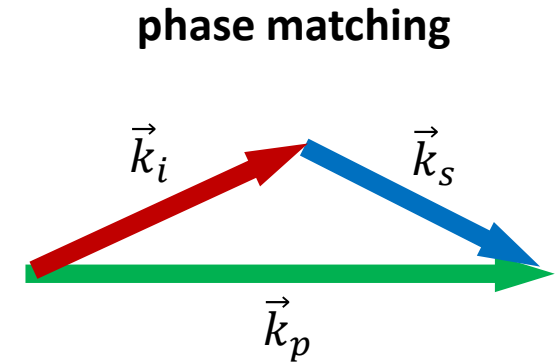
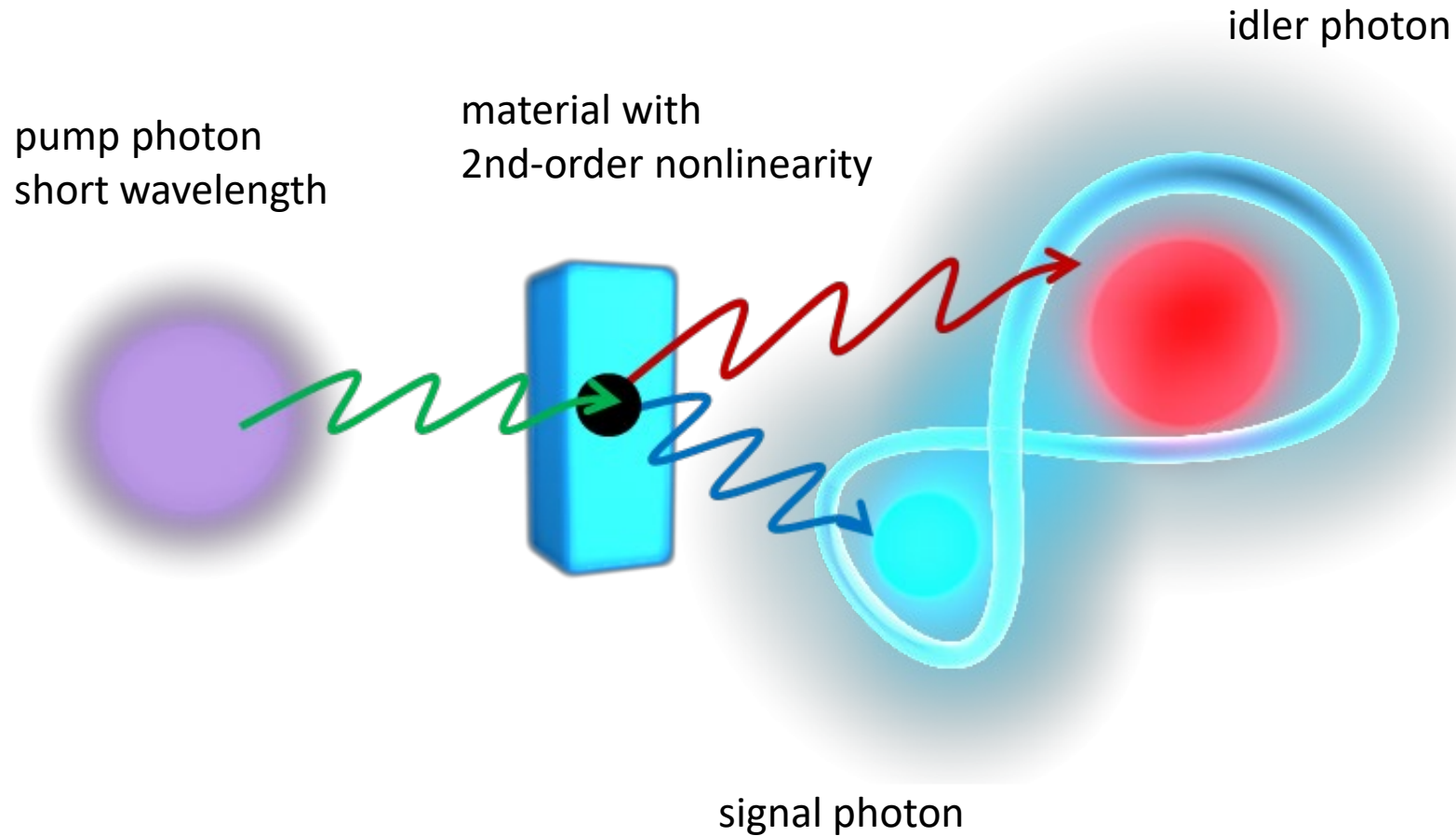

signal / idler can have different wavelength

Photon-pair source for large wavelength separation

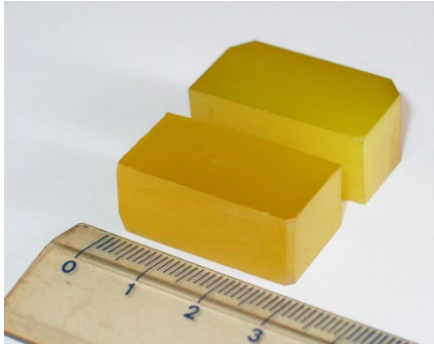

AgGaS₂
Silver Gallium Sulfide

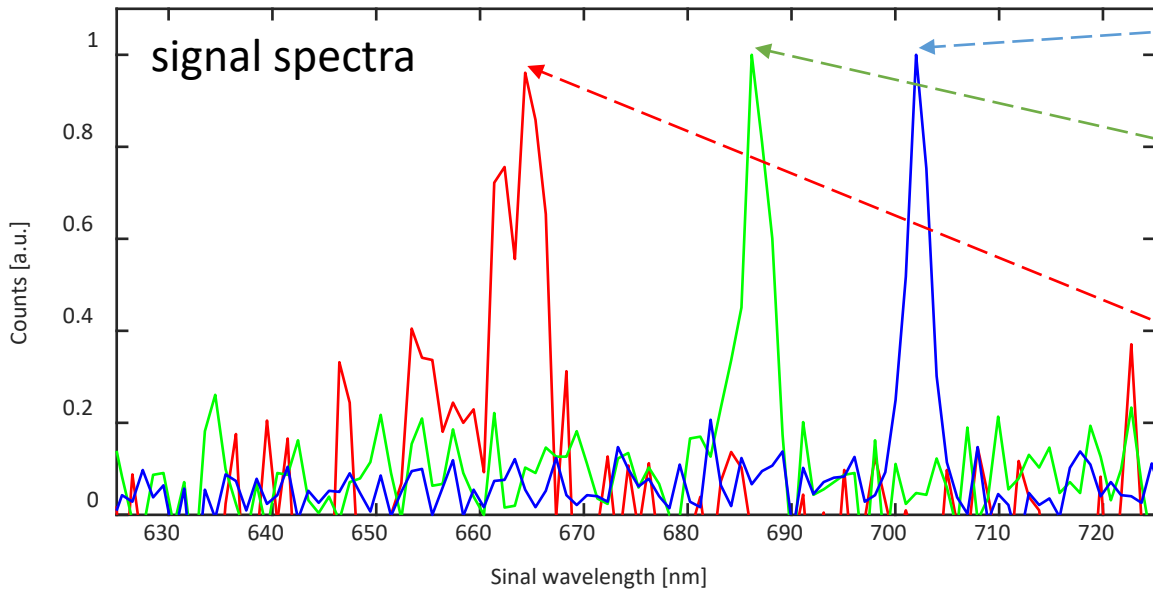
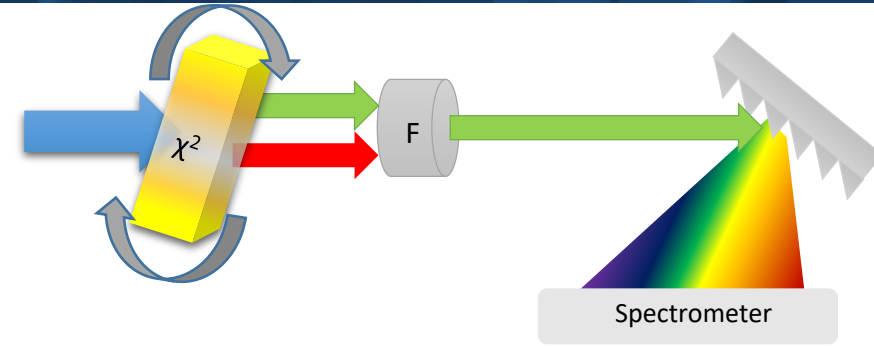

Phase matching curve

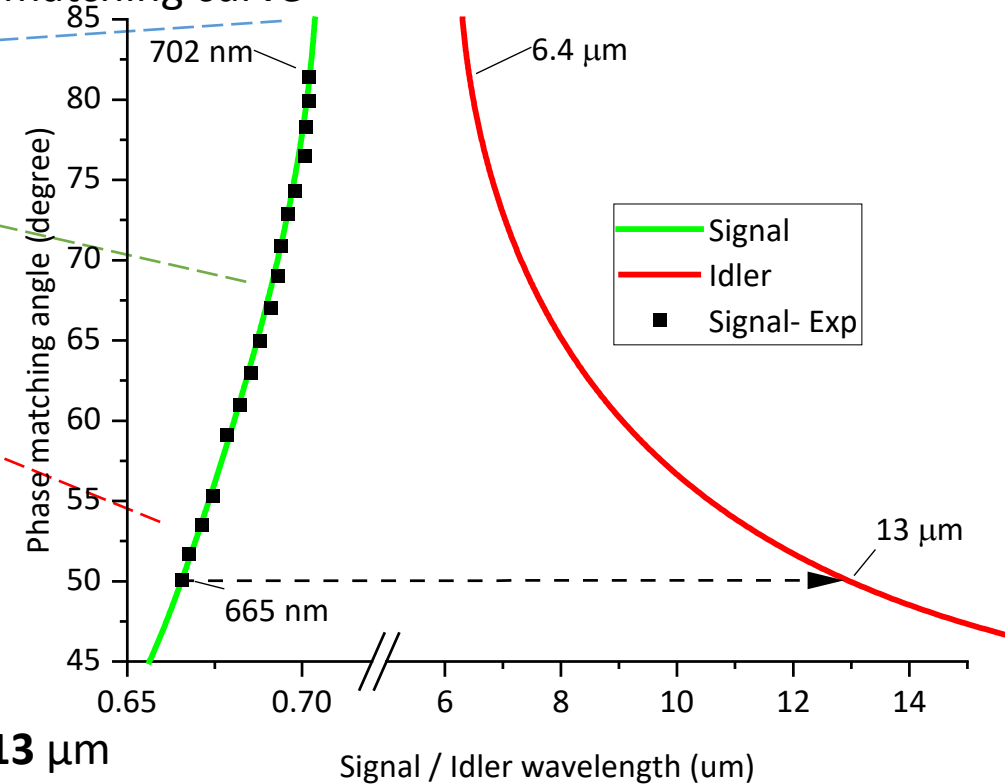

MIR photon pair source with broad tunable spectral range from **6 to 13 μm**
signal in the visible spectral range.

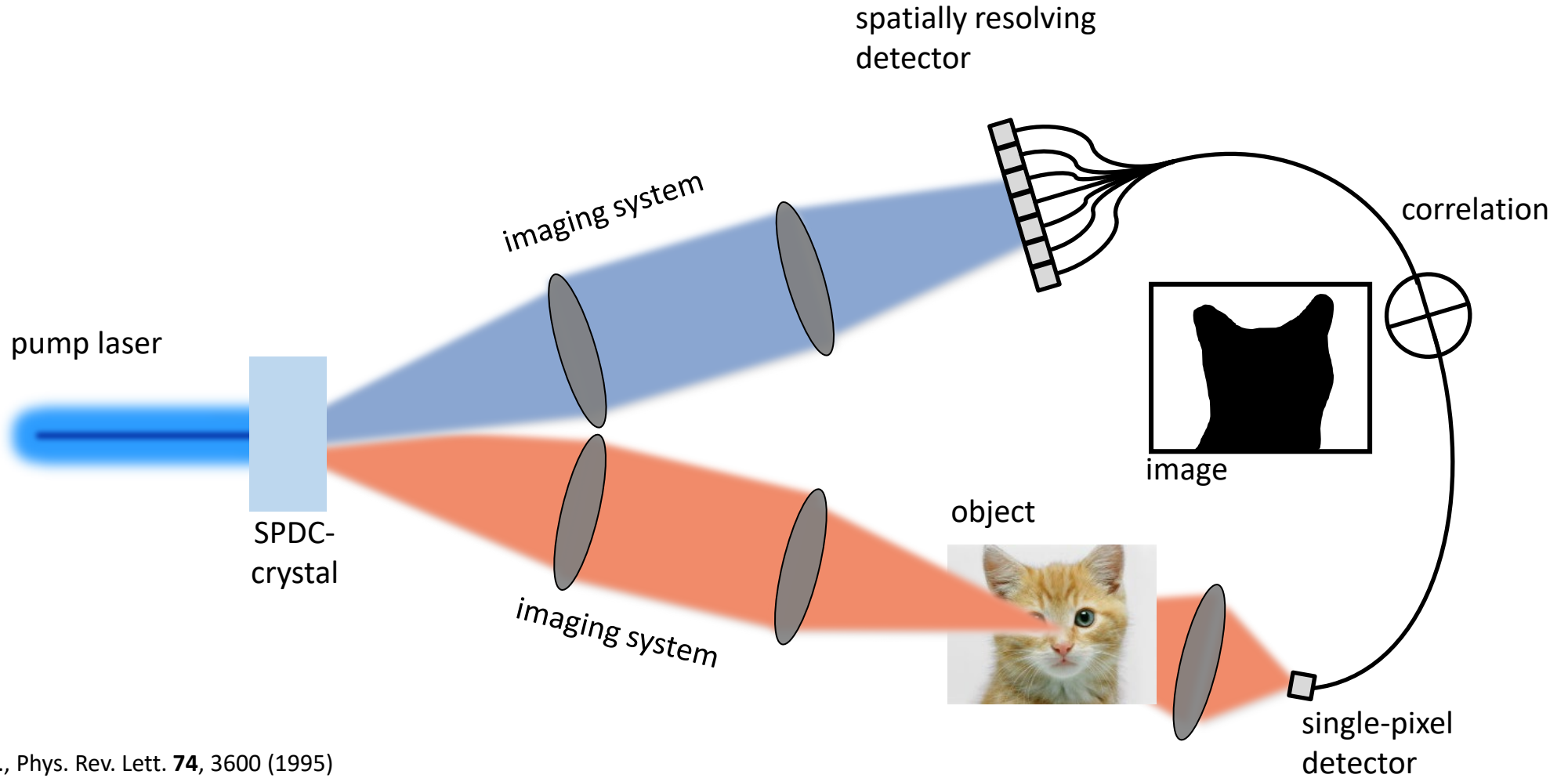

D.V. Strekalov et al., Phys. Rev. Lett. **74**, 3600 (1995)
Rubin, Shi, Phys. Rev. A **78**, 033836 (2008)
Chan, O'Sullivan, Boyd, Phys. Rev. A **79**, 033808 (2009)
Shapiro & Boyd, Quantum Inf Process **11**, 949 (2012)
Moreau et al., Opt. Express **26**, 7528 (2018)

How precise can intensity be measured?

different quantum states lead to different measurement noise

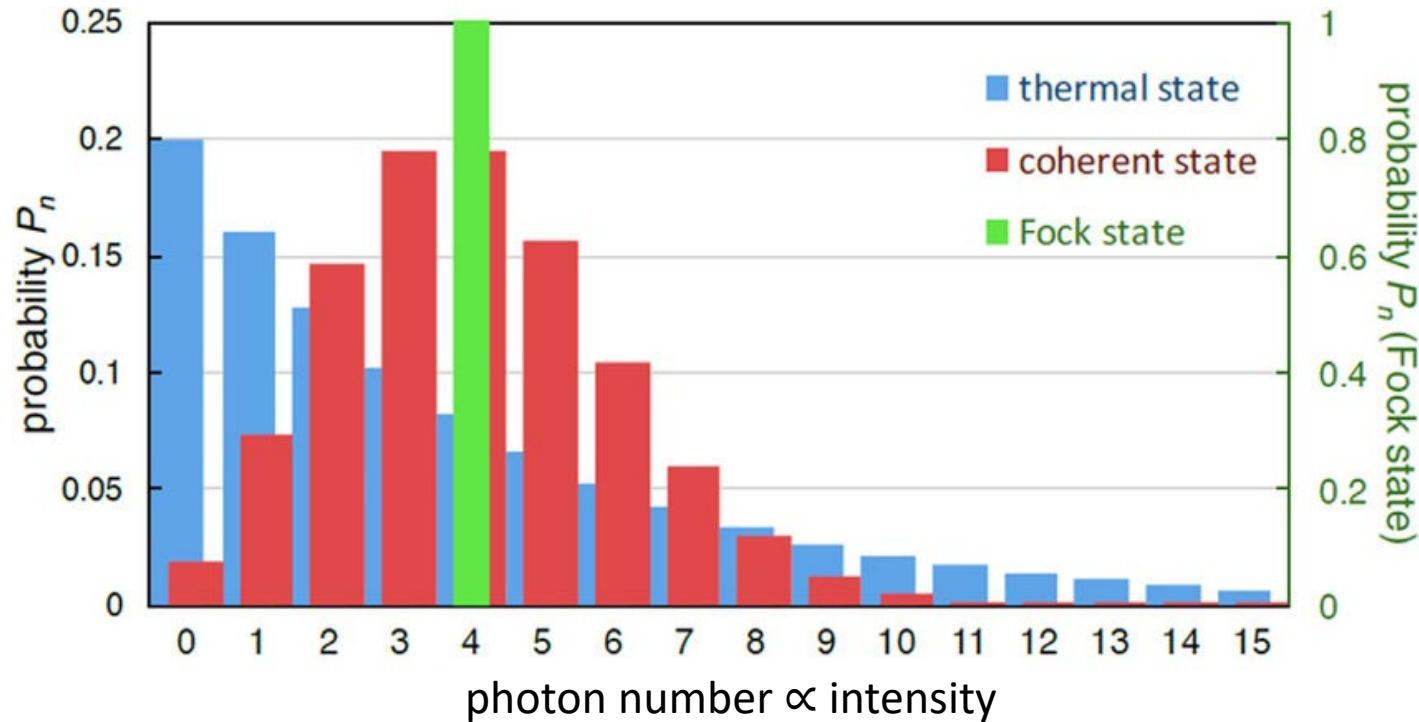

classical shot-noise limit reached by coherent state

Fock / number states can reach Heisenberg limit

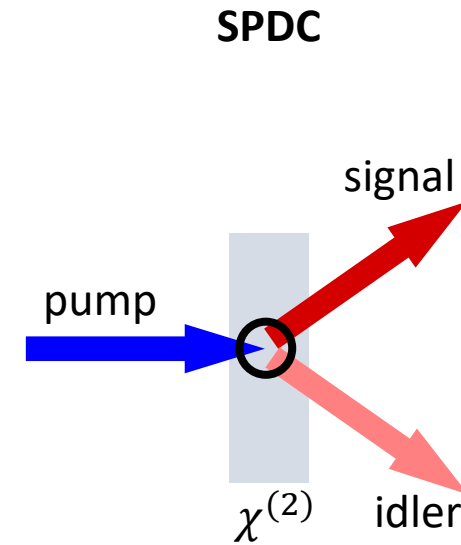

generates pairs of photons

→ detection of signal projects idler in single-photon Fock state

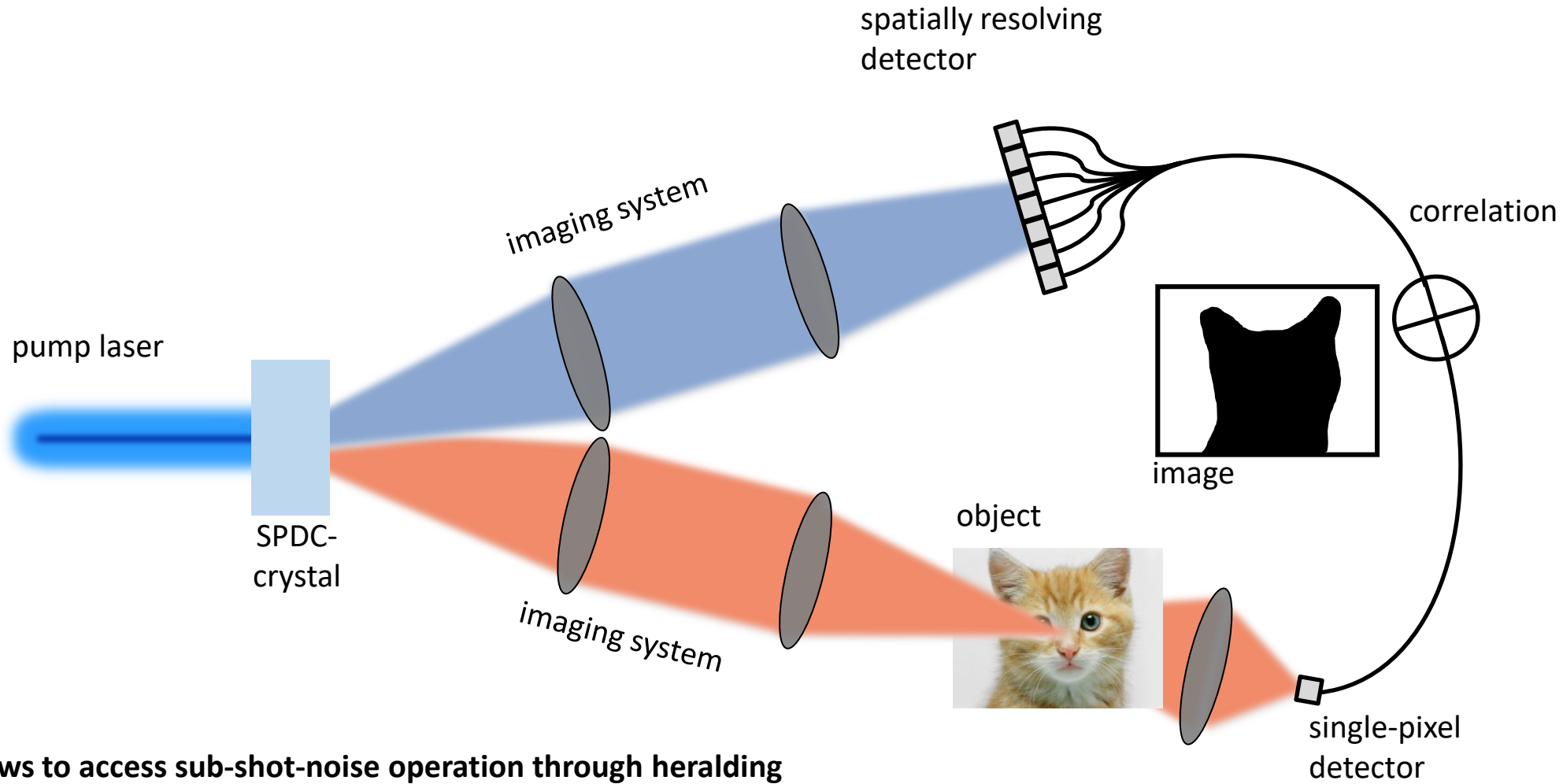

allows to access sub-shot-noise operation through heralding

does not need camera for wavelength interacting with object

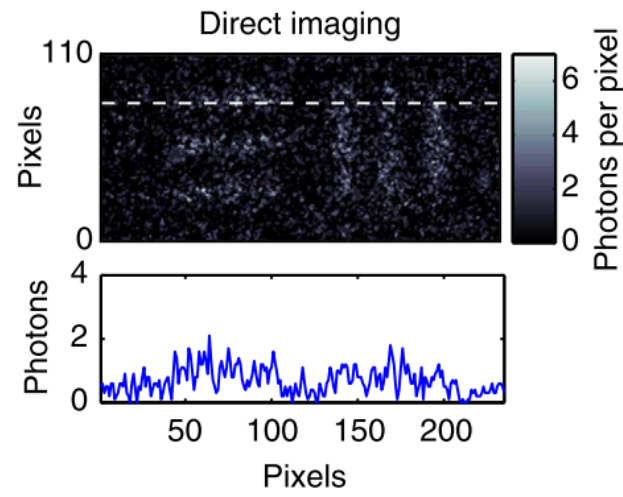
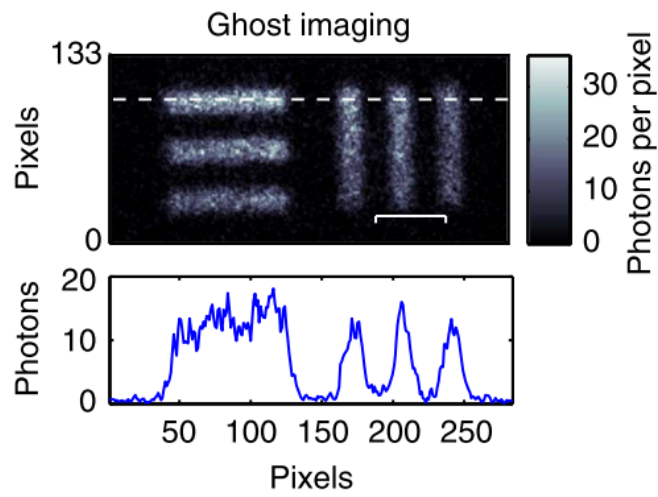
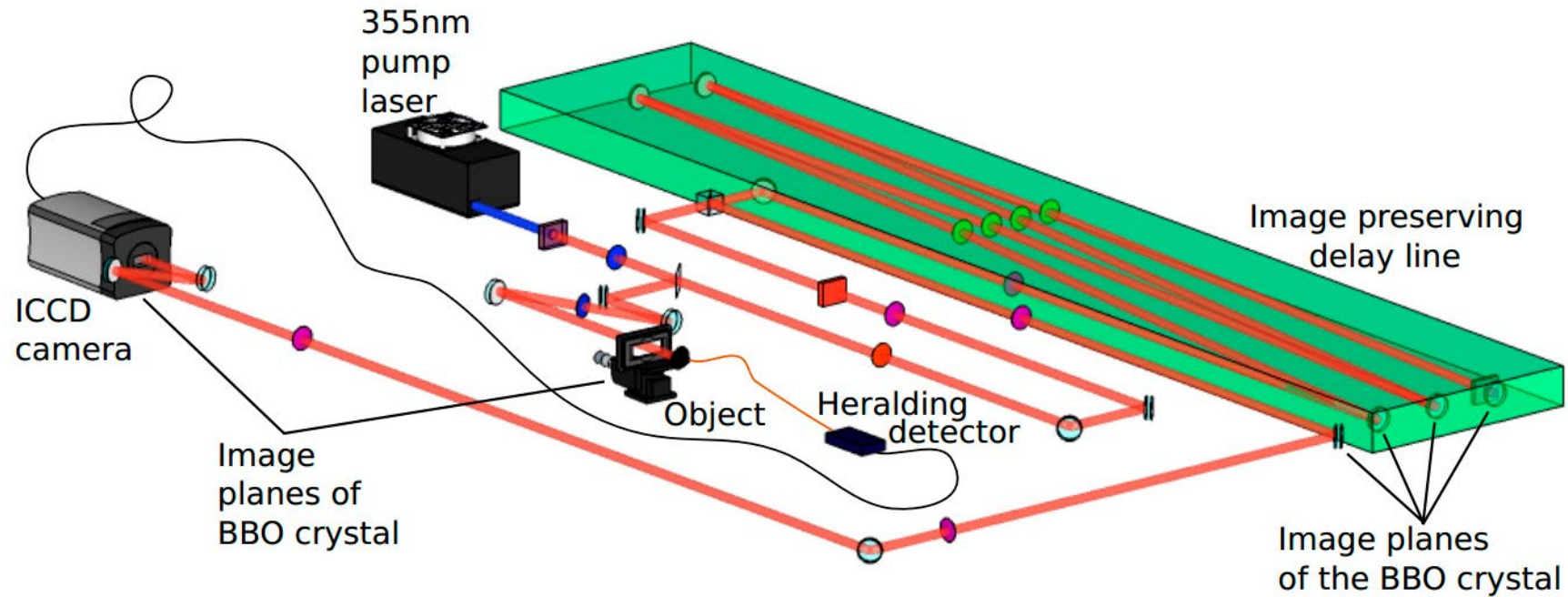

Quantum ghost imaging with SPAD array

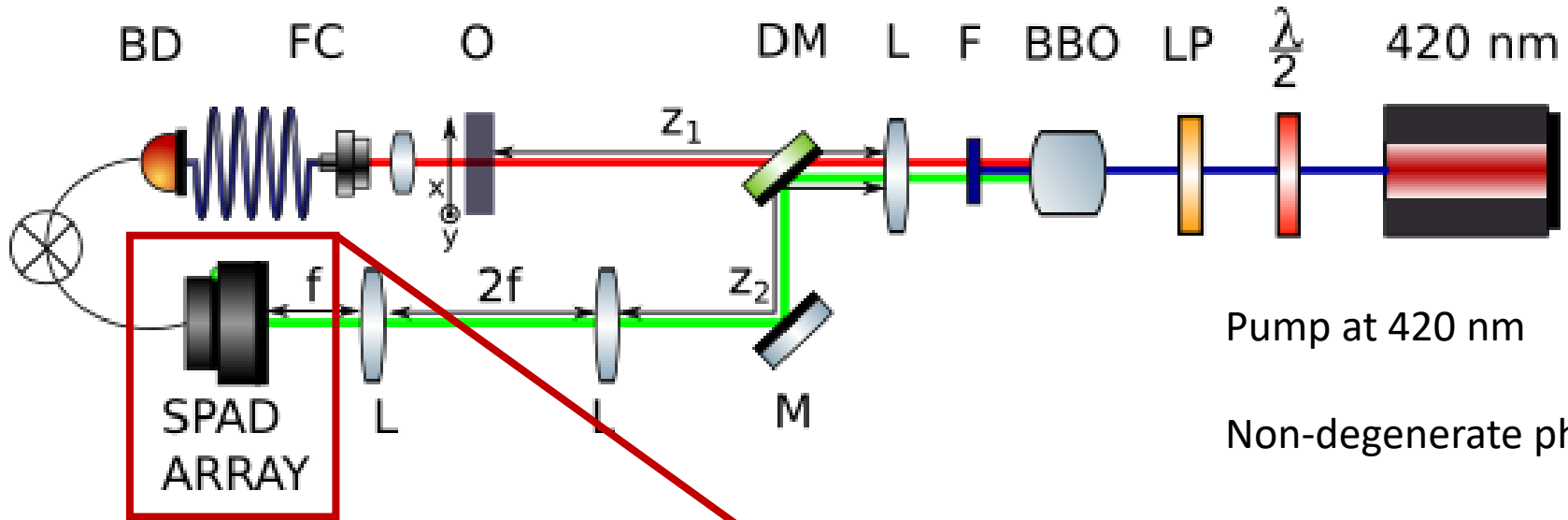

Pump at 420 nm

Non-degenerate photon pairs at 1400 nm and 600 nm

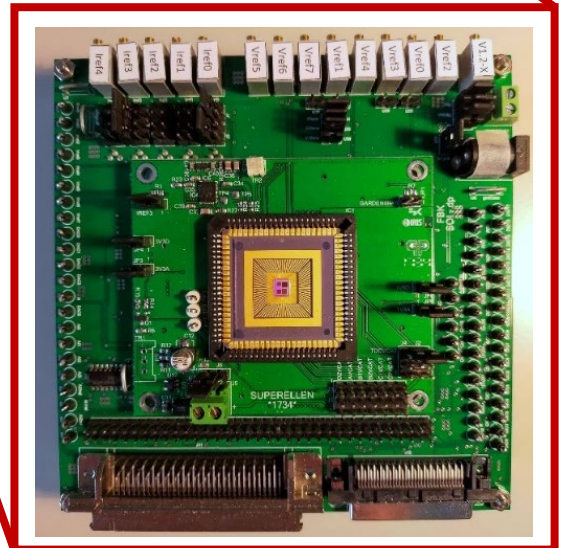

as visible camera, we use SPAD array with 30 x 30 individual Si SPADs

can be directly correlated with signal from single InGaAs SPAD for IR photon

Quantum ghost imaging with SPAD array

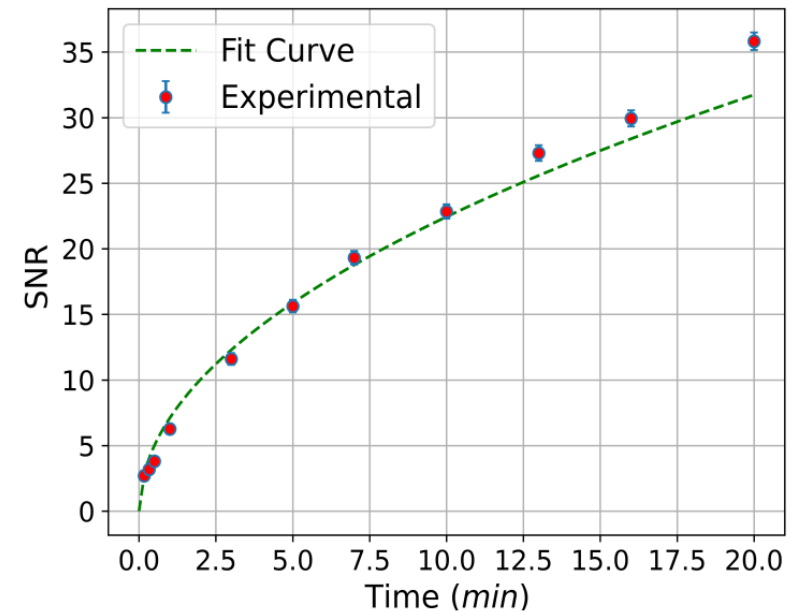
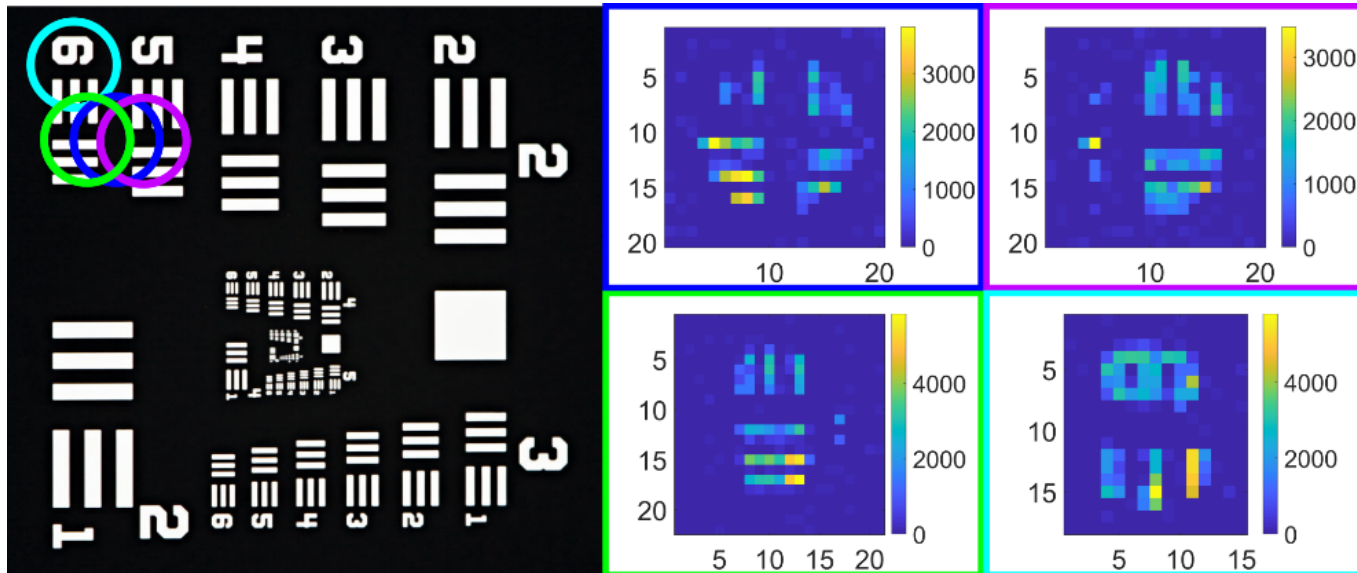
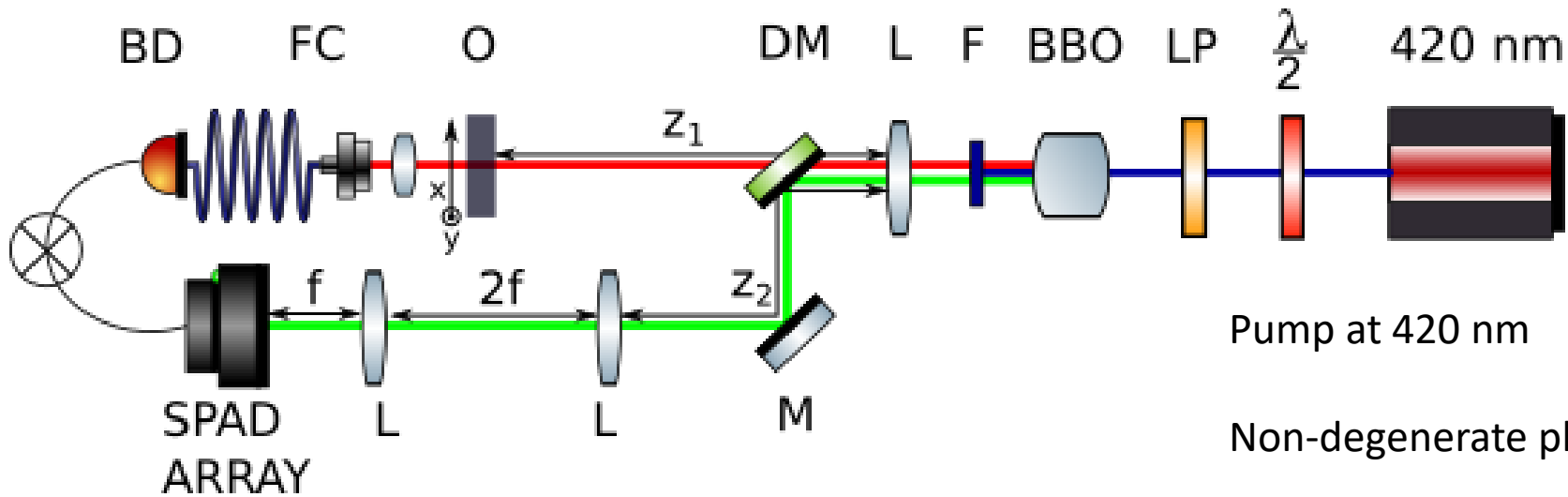

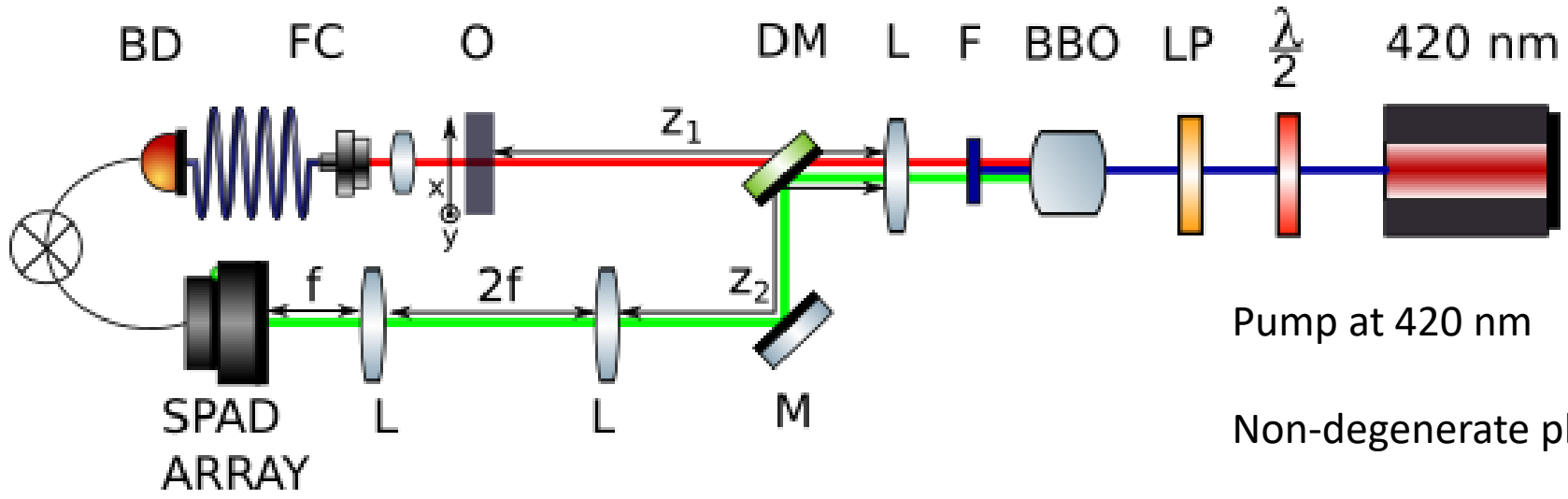

imaging of Au on Si microstructures with VIS camera

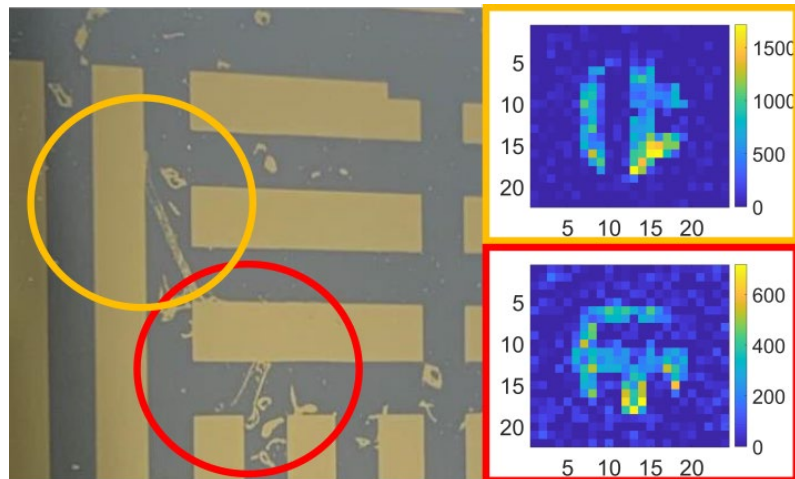

→ can distinguish different IR properties

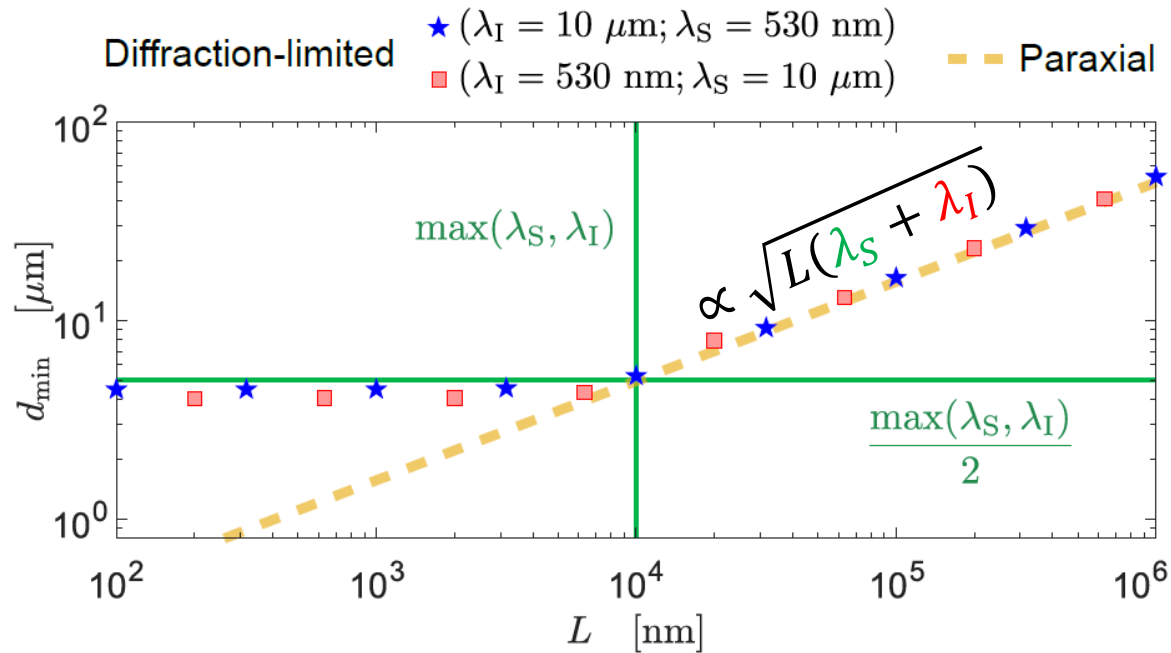

joint angular spectrum of ultrathin source

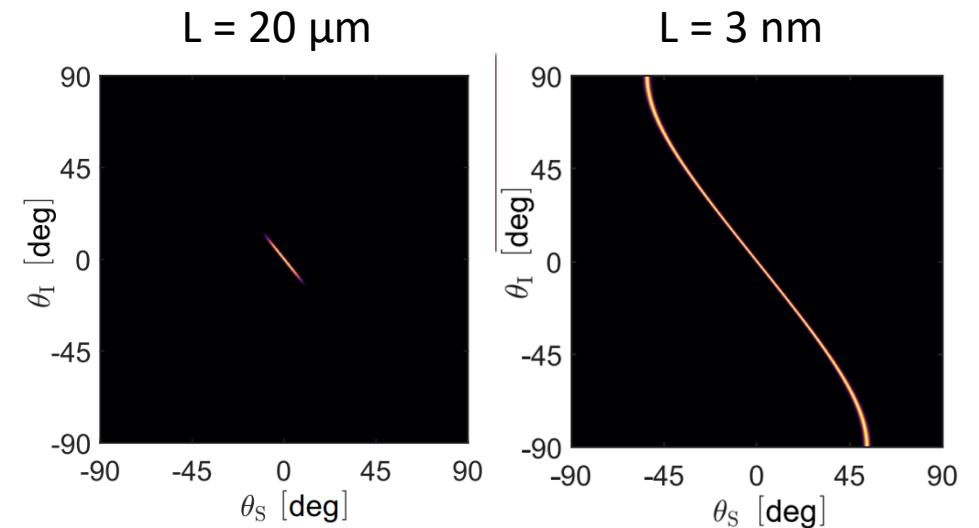

$$\lambda_S / \lambda_I = 0.8$$

achievable resolution limited by longest wavelength $d_{\min} \approx \frac{\max(\lambda_S, \lambda_I)}{2}$

depends on angular bandwidth of photon-pair source

→ shorter sources enable broader angular spectrum of photons, but also limits photon flux

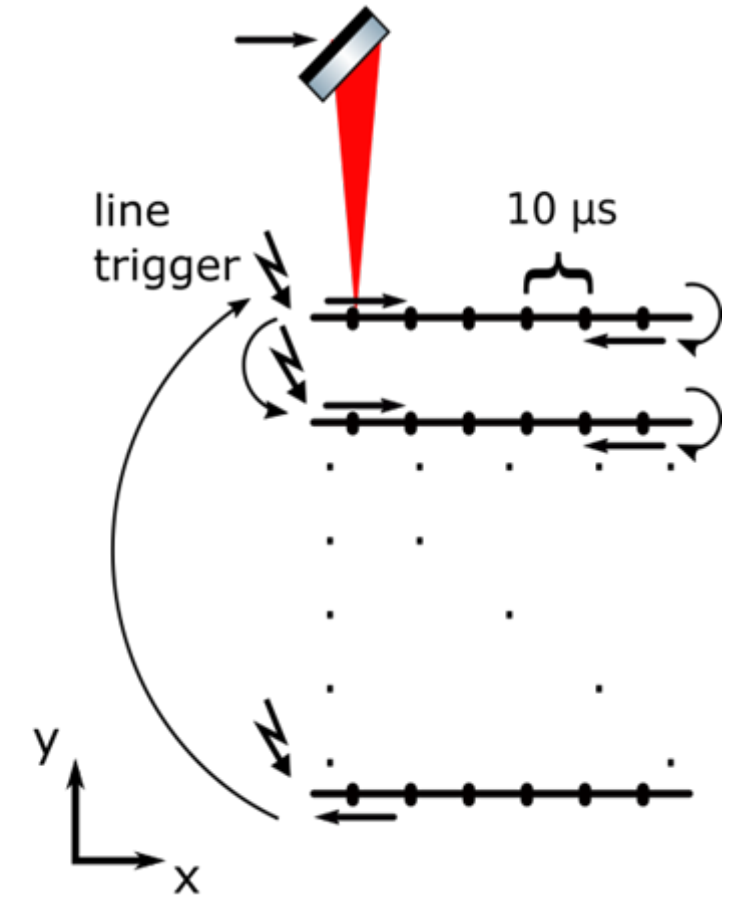
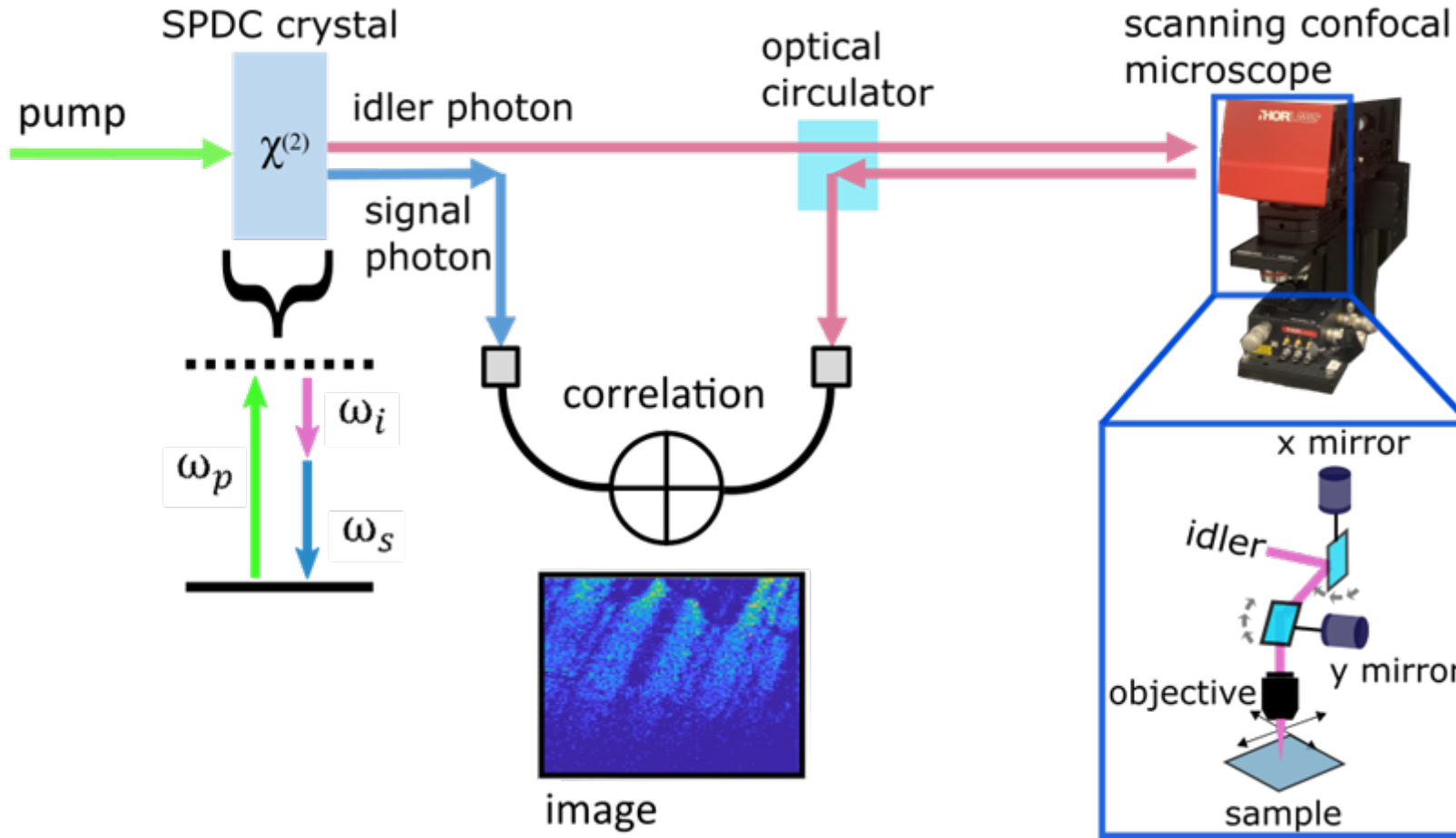

→ decouples properties of source from imaging resolution

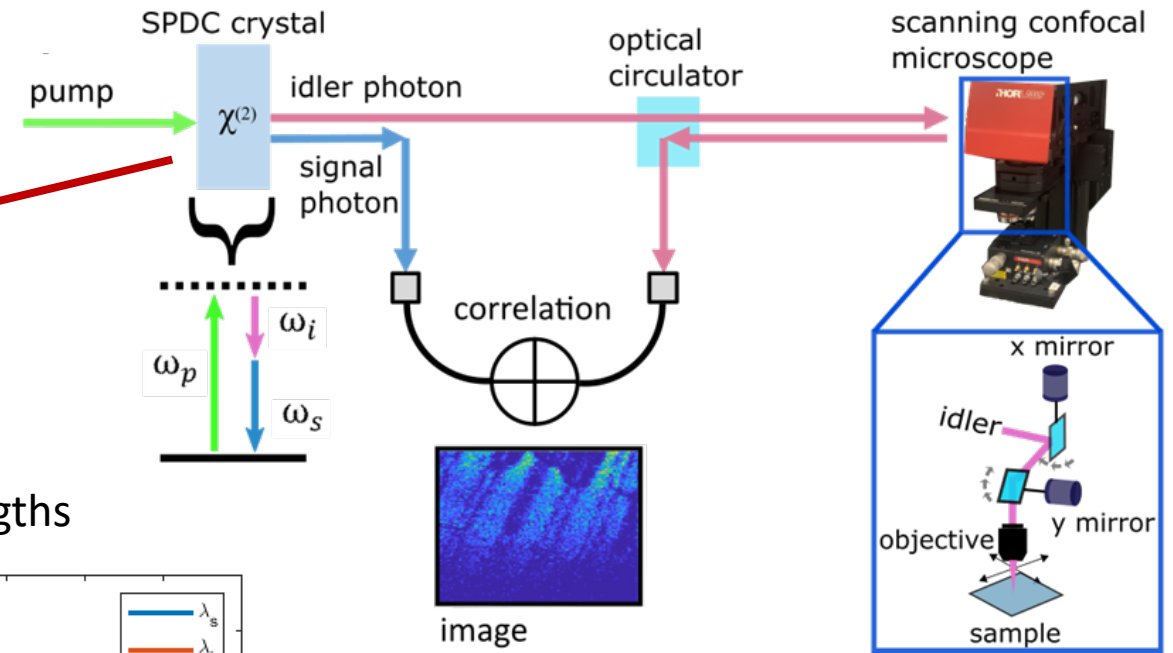
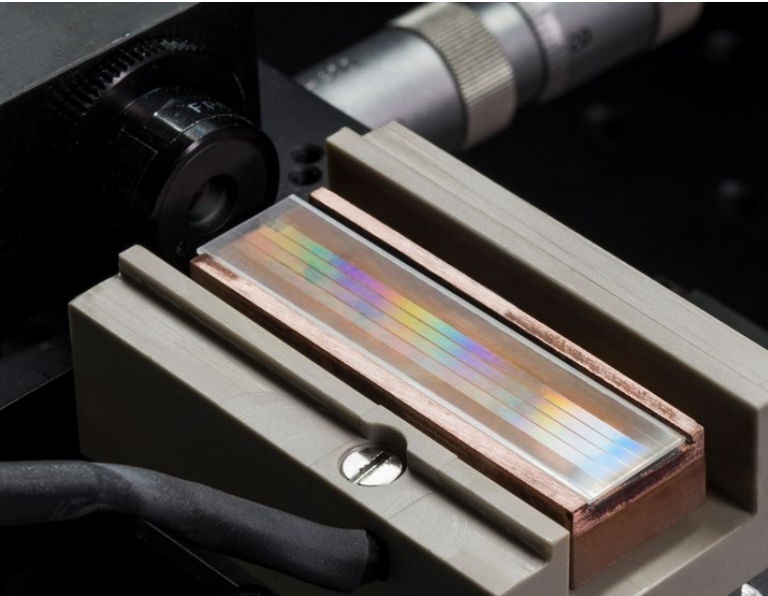

photon vs. pump wavelengths

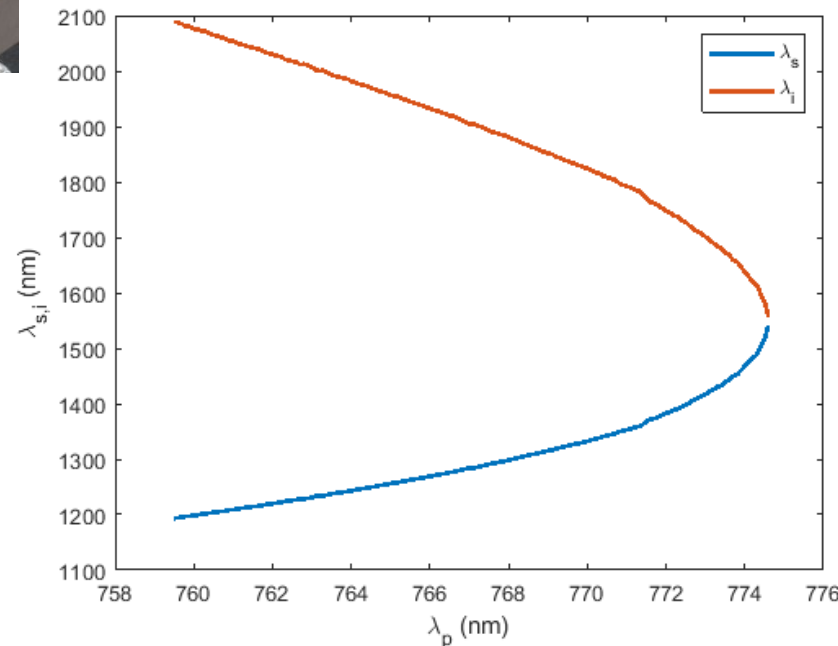

can use waveguide source

provides wavelengths in infrared up to 2 μm

detection with superconducting nanowire detection system

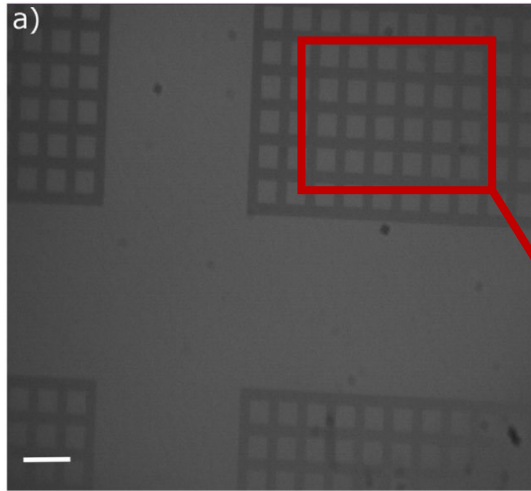

gold grating on glass substrate

image quality can be improved by adding several image frames

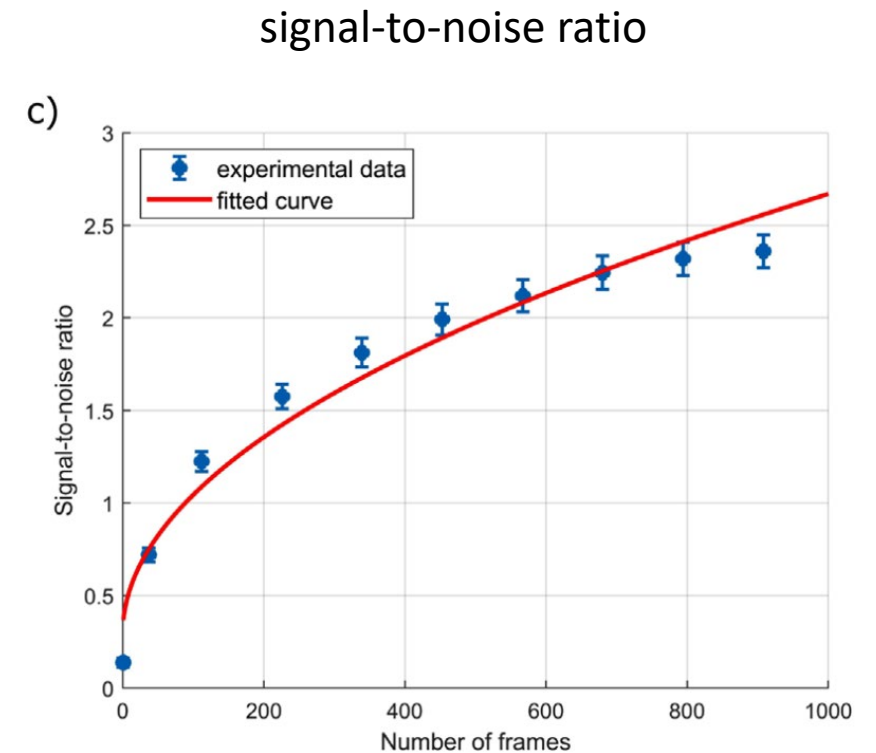
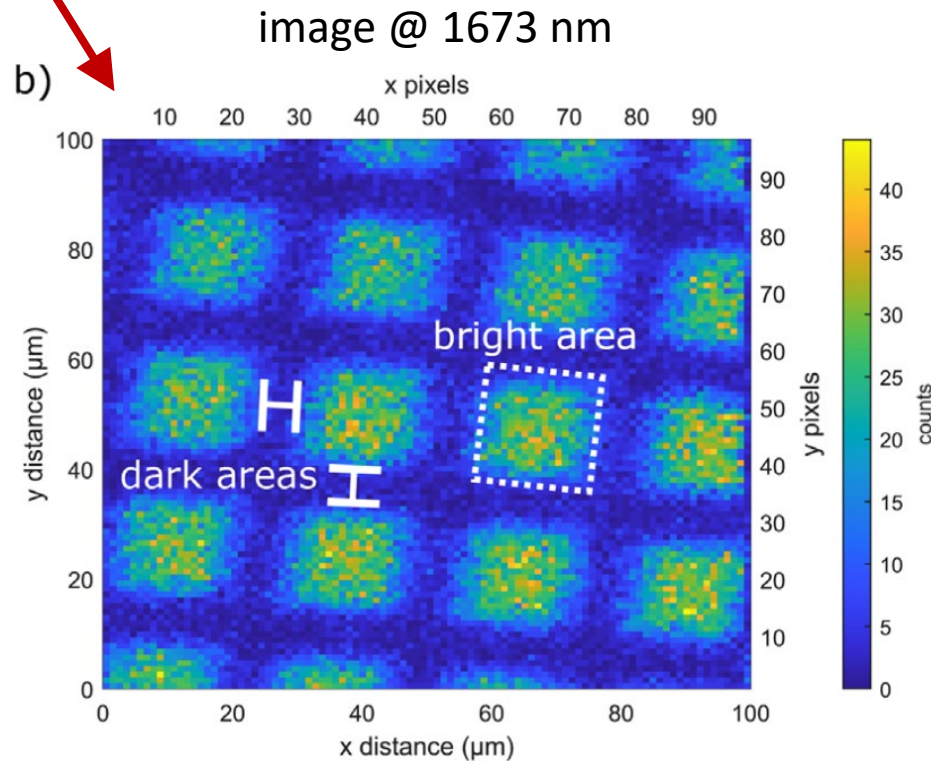

Resolution test with a gold grating at 1673nm

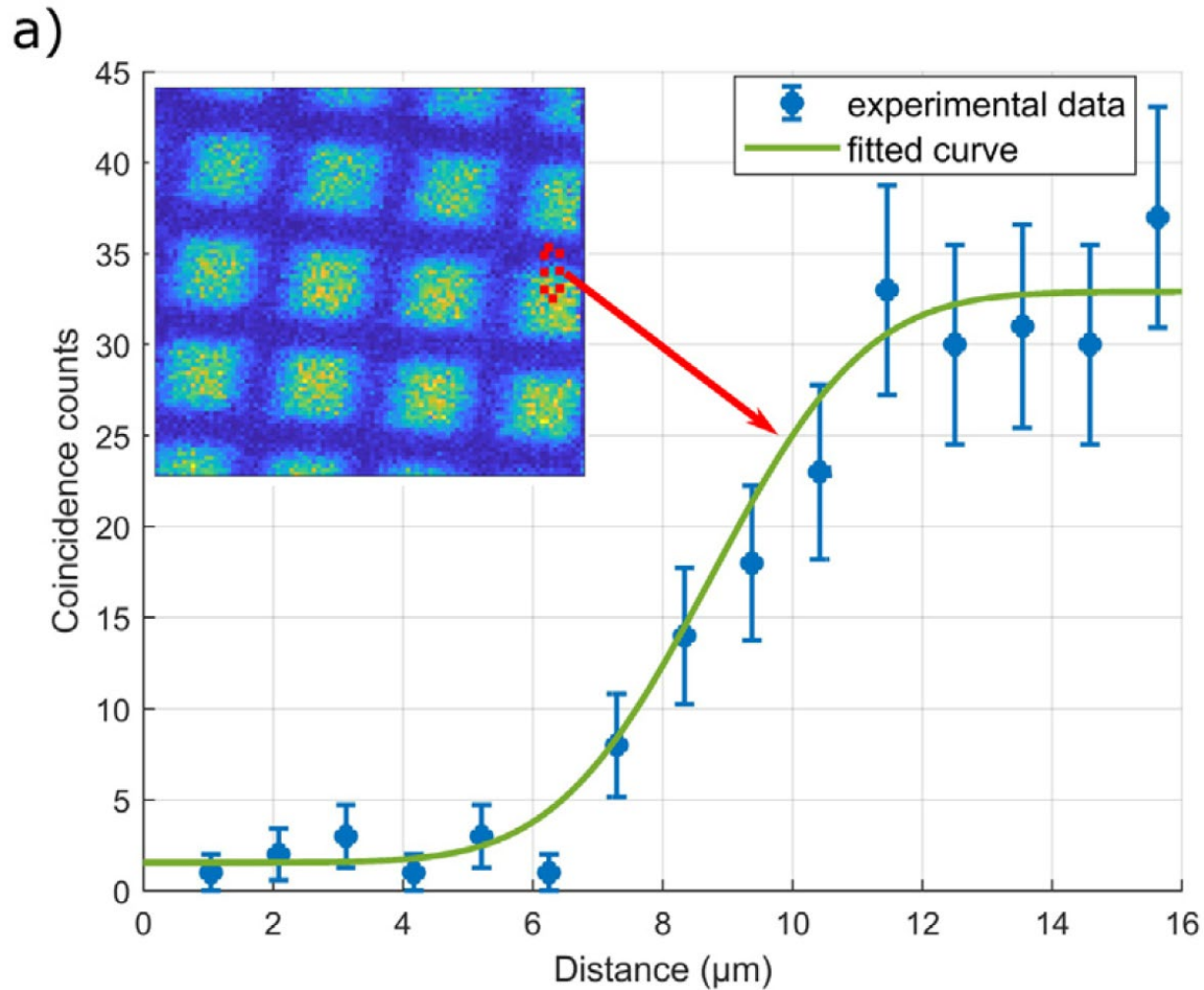

- Resolution estimated with edge-response criterion.
- Data fitted with error function $N(x) = \frac{1}{2}A \operatorname{erf}\left(\frac{x - (\mu - a)}{\sqrt{2}\sigma}\right)$
- Resolution close to diffraction limit, $1.25 \mu\text{m}$ for $\text{NA} = 0.5$
- Resolution limited only by optics, not by nonlinear crystal.

- Preliminary test on onion epithelial cells.
- Capability to resolve nuclei

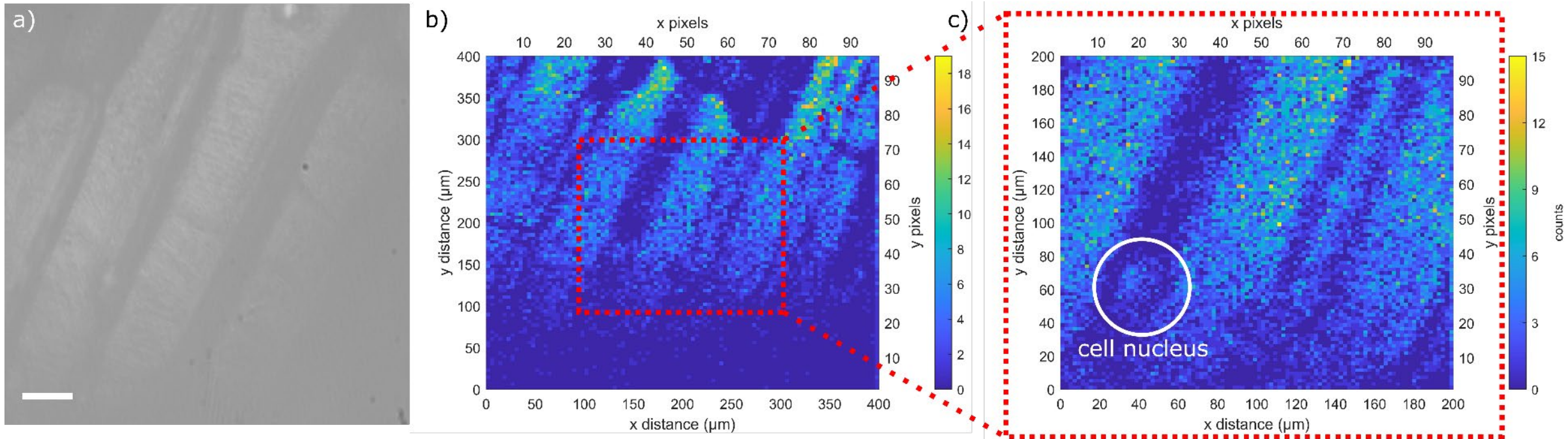

classical microscope @ VIS

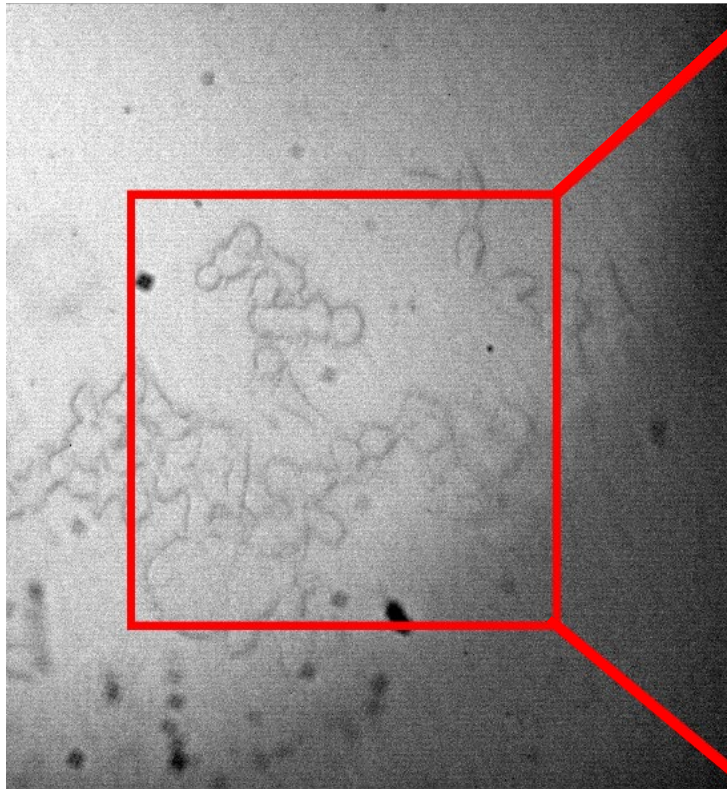

quantum scanning microscope @ 1650 nm

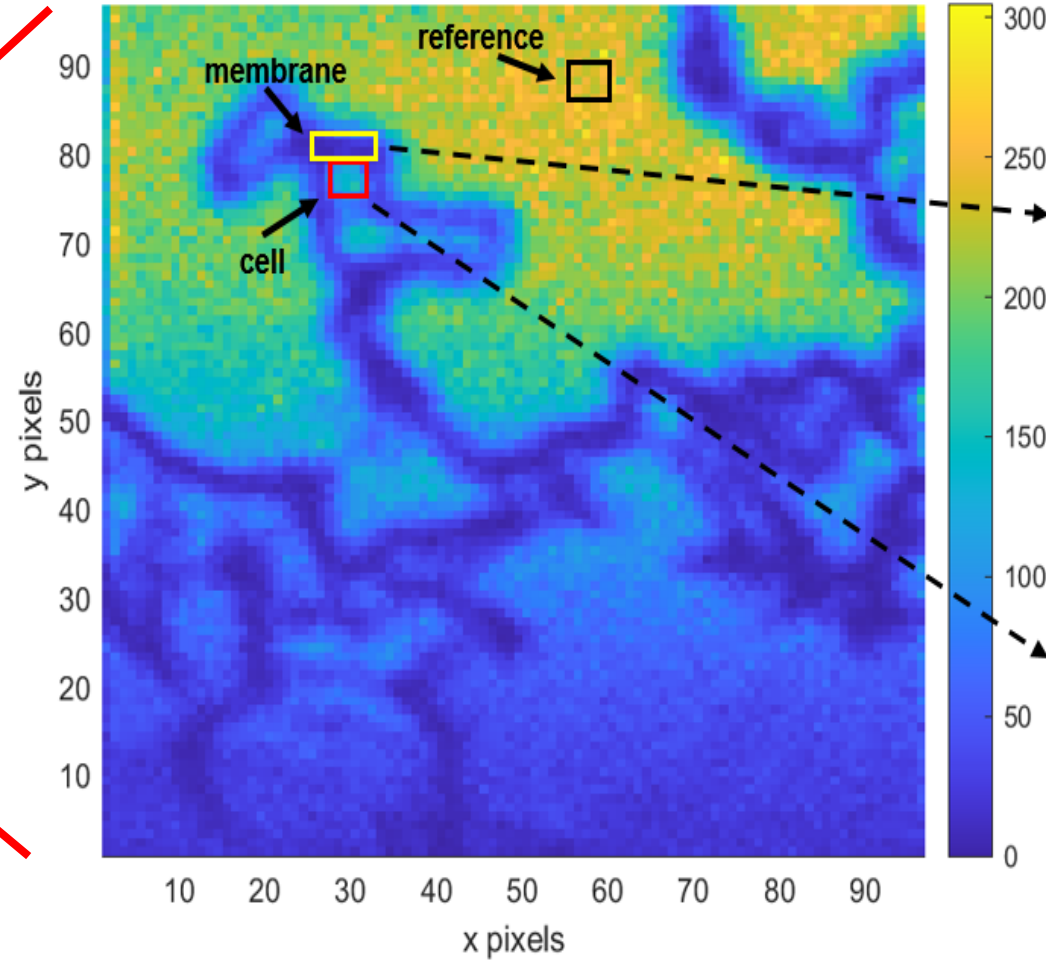

spectra

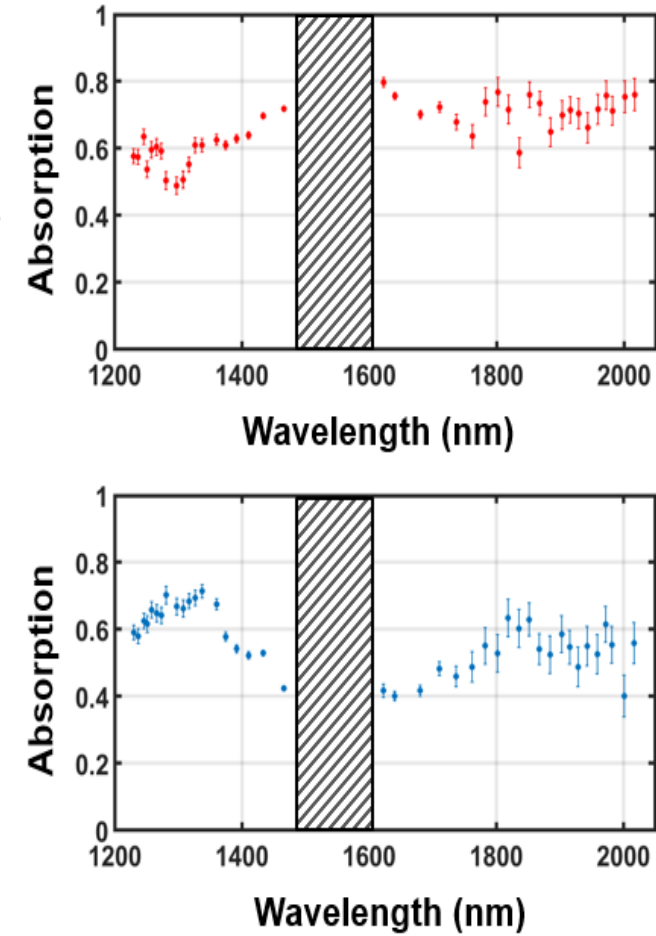

experimentally realized quantum ghost imaging with SPAD array

resolution fundamentally limited by photon-pair source

implemented scanning quantum imaging in standard microscope

achieved diffraction-limited resolution

first test of biological object

